

Solar energy collection by antennas

Author:

Corkish, Richard Paul; Green, M.A.; Puzzer, T.

Publication details:

Solar Energy Journal

v. 73

Chapter No. 6

pp. 395-401

Publication Date:

2002

Publisher DOI:

[http://dx.doi.org/10.1016/S0038-092X\(03\)00033-1](http://dx.doi.org/10.1016/S0038-092X(03)00033-1)

License:

<https://creativecommons.org/licenses/by-nc-nd/3.0/au/>

Link to license to see what you are allowed to do with this resource.

Downloaded from <http://hdl.handle.net/1959.4/40066> in <https://unsworks.unsw.edu.au> on 2024-04-25

SOLAR ENERGY COLLECTION BY ANTENNAS

R. Corkish¹, M.A. Green and T. Puzzer

Centre for Advanced Silicon Photovoltaics and Photonics, University of New South Wales,
Sydney NSW 2052, Australia

Phone: +61 2 9385 4068, Fax: +61 2 9662 4240

r.corkish@unsw.edu.au

ABSTRACT: The idea of collecting solar electromagnetic radiation with antenna-rectifier (rectenna) structures was proposed three decades ago but has not yet been achieved. The idea has been promoted as having potential to achieve efficiency approaching 100% but thermodynamic considerations imply a lower limit of 85.4% for a non-frequency-selective rectenna and 86.8% for one with infinite selectivity, assuming maximal concentration in each case. This paper reviews the history and technical context of solar rectennas and discusses the major issues: thermodynamic efficiency limits, rectifier operation at optical frequencies, harmonics production and electrical noise.

1 INTRODUCTION

Solar cells, with the exception of their anti-reflection coatings, are quantum devices, only able to be understood and designed by application of quantum physics. However, the wave nature of light is routinely exploited at longer wavelengths in radio and microwave frequency bands. Photon energies are low at radio frequencies and a large number is required to give some particular power density. We tend to use wave models in that regime. At short wavelengths fewer photons are required for the same power density and we tend to use particle models. In principle, there may be no reason why the electromagnetic wave technologies which are so successfully used for radio cannot be scaled to optical frequencies, although quantum models may be necessary for at least some aspects, but there are significant practical issues, especially the sub- μm size scales involved.

A rectenna, or rectifying antenna, is a device for the conversion of electromagnetic energy propagating through space to direct current in a circuit. It has one or more elements, each consisting of an antenna, filter circuits and a rectifying diode or bridge rectifier either for each antenna element or for the power from several elements combined.

¹ ISES member

This short paper briefly reviews the history of solar rectenna ideas, sets them in their technological and scientific context, discusses efficiency limits and mentions some issues which still need resolution. Some of this work was presented at the “PV in Europe” conference, 2002 (Corkish and Green, 2002).

2 HISTORY OF SOLAR RECTENNAS

Bailey proposed the idea of collecting solar energy with devices based on the wave nature of light in 1972 (Bailey, 1972, Bailey et al., 1975). He suggested artificial pyramid or cone structures analogous to those found in nature and similar to dielectric rod antennas. His paper describes pairs of the pyramids as modified dipole antennas, each pair electrically connected to a diode (half wave rectifier), low-pass filter and load. The antenna elements needed to be several wavelengths long to permit easier fabrication.

Marks (1984) patented the use of arrays of submicron crossed dipoles on an insulating sheet with fast full-wave rectification. This differed in a number of ways from Bailey’s proposal, most importantly in that Marks’ structure was essentially a conventional broadside array antenna with the output signal from several dipoles feeding into a transmission line to convey their combined power to a rectifier. This design requires the oscillations from each dipole to add in phase. Kraus (1988, pp. 715-6) proposed two orthogonally-polarised arrays, one above the other with the front one supported by a transparent substrate and a reflector below them (Fig. 2).

Marks also patented devices to collect and convert solar energy using solidified sheets containing oriented metal dipole particles or molecules (Marks, 1986) and a later patent (Marks, 1988) describes antenna-like cylinders, each with an asymmetrical metal-insulator-metal (MIM) diode for rectification. Marks also invented a system (Marks, 1990, Marks, 1991) in which a plastic film containing parallel chains of iodine molecules form linear conducting elements for the collection of optical energy. The (theoretical) conversion efficiency was claimed to be 72% (Marks, 1990) or, elsewhere, > 80% (Marks, 2002).

Lin et al. (1996) reported the first experimental evidence for light absorption in a fabricated resonant nanostructure and rectification at light frequency in a test structure. The device used grooves and deposited metallic elements to form a parallel dipole antenna array on a silicon substrate and a p-n junction for rectification. They observed an output resonant with the dipole length and dependent on light polarization and angle of the incoming light, indicating that the device indeed possessed antenna-like characteristics.

ITN Energy Systems Inc. ITN is investigating optical antennas coupled to fast tunnel diodes (Berland et al., 2001). Berland et al. state that the limiting efficiency is >85%. ITN have built model dipole rectenna (rectifying antenna) arrays operating in the microwave range at 10 GHz, achieving >50% conversion efficiency and have integrated metal-insulator-metal rectifier diodes in a μm -scale antenna. Their initial goal was to demonstrate the feasibility of high-efficiency optical frequency technology at a single wavelength (Berland et al., 2001). ITN’s collaboration with the US National Institute of Standards and Technology

(NIST, 2002) has made infrared rectenna structures with metal-insulator-metal diodes between dipoles for operation at 30 THz (10 μm wavelength) by atomic layer deposition. The University of Florida has been investigating the application of SiC crystals as antennas for solar energy collection (Goswami, 2001, Anon., 1992).

3 RELATED TECHNOLOGIES

A solar rectenna is similar to a simple radio telescope or radiometer (Burke and Graham-Smith, 1997) except that the radio telescope needs to *measure* the radiative power received through the antenna, often with a square-law detector which produces an output voltage proportional to the input power, while the rectenna needs to *convert* that power to useful work. There are also other technologies of relevance.

3.1 Microwave rectennas

The dream of wireless electrical power transmission, especially to or from or in space (Hirshman, 2001), has prompted an intense research effort (Brown, 1984), beginning with Tesla in 1899. Theoretical and experimental work has been carried out for wavelengths of 122 - 3 mm. Rectenna efficiencies (microwave to DC) have been measured in excess of 80% at a single frequency (Konovaltsev et al., 2001, Brown, 1970).

3.2 Radio-powered devices

There is a range of low-power electronic devices which derive their operating power from electromagnetic fields. The earliest radio receivers, crystal sets, were self powered by rectification of the incoming radio frequency signal. Several inventors have developed devices to monitor microwave oven leakage or other radiation hazards by powering an indicator from the leaking radiation via a rectenna . A similar method has been used to power active biotelemetry devices, implanted therapeutic devices, radio frequency identification tags and transponders and even the proposed recharging of batteries in microwave ovens.

3.3 Optical and infrared antennas and diodes

Optical and infrared antennas and antenna-coupled detectors are being researched for a range of applications. In the optical spectral range, R.J. Green has developed an optical antenna for communications (Green, 2002). Others have developed bow-tie antenna structures as probes for scanning near-field optical microscopy (Oesterschulze et al., 2001). Fumeaux et al. measured the performance of an lithographic infrared antenna at optical frequencies and observed a polarization-dependent response (1999). The response of nanometre-scale metallic antennas have been simulated and applications proposed in the fields of diagnostic imaging and the detection of chemical or biological agents (Podolskiy et al., 2002) and there has been extensive research on

infrared antenna devices intended to enhance the coupling into solid state photoconductive or photovoltaic detectors (Christodoulou and Wahid, 2001).

Extremely fast operation is required for optical-frequency rectification, implying small size (Lin et al., 1996). Metal-insulator-metal (MIM) tunnelling devices are often chosen for such applications (Wang, 1976, Elchinger et al., 1976). Early MIM devices were “cat’s whisker” diodes but modern diodes of this type are formed from deposited metal films and thin oxides.

3.4 Ratchets and Brownian motors

It is well known that in systems far from thermal equilibrium it is possible to rectify unbiased noise by breaking spatial inversion symmetry. The research field of Brownian motors and ratchets is reviewed by Reimann (Reimann, 2002). The work of Song (Song, 2002) and colleagues has resulted in InGaAs-InP ballistic electron devices able to rectify 50 GHz electromagnetic radiation at room temperature. They are essentially artificial photogalvanic nanocrystals (Belinicher and Sturman, 1980). Similar structures may potentially be useful at even higher frequencies but their upper frequency limit has not yet been established. The upper limit may be set by the distance an electron can travel ballistically during a half cycle of the incident field (assuming a quasi-monochromatic source, for now). Linear polarisation splitting of sunlight would be a necessary prerequisite for solar energy conversion. The host material for the ratchet would need to have bandgap energy exceeding the photon energy of the incident radiation to avoid the absorption process that is usually encouraged in solar cells but which would be detrimental here. Such a device would be converting energy that is normally lost through free carrier absorption in a solar cell.

4 SOLAR RECTENNAS

4.1 Filtering

Two filters are usually employed in rectennas (McSpadden et al., 1998, Nahas, 1975). An input filter between the antenna and the rectifier must (a) form an impedance match between the antenna and the subsequent circuitry, (b) ensure a continuous current path for power flow from the antenna despite the intermittent nature of the rectifier current, and (c) prevent the re-radiation by the antenna of harmonic energy produced by the non-linear load presented by the rectifier (Brown, 1970). It was found that power flow continuity was able to be achieved, even with half-wave rectification, by suitable filter design (Raytheon, 1975). A choke or L-type output filter following the rectifier should also achieve the desired result. Harmonic generation is a fundamental result of the rectification process and its re-radiation is a potential problem because it can result in lost power and interference. Several designs are available in the literature for efficient rectifying microwave power converters (Nahas, 1975, McSpadden et al., 1996, Razban et al., 1985). Output filtering is necessary to smooth the rectified signal to DC.

In the case of solar energy collection with rectennas, there is an additional problem of the wide bandwidth necessary to encompass the solar spectrum (wavelength range of $0.2 - 2 \mu\text{m}$ corresponds to approx. $150 - 1500 \text{ THz}$). The above requirements will be difficult to satisfy over such a spread of frequencies. In particular, it will be difficult to deal with harmonics

arising from the collection of long-wavelength light since some harmonics will be within the desired bandwidth for energy acceptance. It will become necessary to split the spectrum and direct different fractions to different rectennas or to frequency-split the output of a broadband antenna.

4.2 Polarisation

The energy in unpolarised sunlight cannot all be collected by a single antenna element, even at a single frequency. At least two orthogonal elements are required to maximize the power. Prior splitting of sunlight into two orthogonal linear components, by use of birefringent crystals for example, would be necessary for some possible converter designs, such as Song's ratchets (Song, 2002).

4.3 Combining antenna element outputs

Two basic families of designs have been proposed for antenna solar energy collectors. Bailey (1972), for example, had individual pairs of antenna elements each supplying its own rectifier and the DC rectifier outputs were combined. Kraus (1988), for example, on the other hand, combined the electrical oscillations from many antenna elements in a particular phase relationship and delivered their combined output to a rectifier. With the former method there is the immediate concern that the tiny power expected from one or two antenna elements may not be enough to produce sufficient voltage to allow proper operation of any conceivable actual rectifier diode. The latter approach overcomes that problem but at the expense of the need for spatial coherence across all the antenna elements feeding a rectifier.

4.4 Antenna size and coherence

The beamwidth, or acceptance angle, of an array antenna is related to its size in wavelengths. In this case, for maximum concentration, we would seek to confine the main beam to the solar disk, of around 30 arc minutes angular extent. This would require a square or circular array of about 100 wavelengths across (Elliott, 1963). Metallic structures for this application may need to be limited to a few nm thickness (Podolskiy et al., 2002).

At least partial coherence is needed across an array to ensure that the components from the antenna elements combine constructively. The transverse coherence distance for the solar disk is around 50 μm (Graham-Smith and King, 2000), roughly consistent with the array size needed to satisfy the beamwidth requirement, above. However, the issue of temporal coherence along the direction between the sun and the antenna is a more complex issue requiring further examination.

5 EFFICIENCY LIMITS

Bailey (1972) suggested that 100% solar energy conversion efficiency may be possible but he also claimed the same upper limit for photovoltaic converters in general. There was at that time considerable confusion in the literature about whether the Carnot efficiency limit should apply to solar energy conversion (Bailey, 1980). Today, it is not questioned that it does and, indeed, more restrictive limits apply for most conceivable converter structures. Kraus (1988) also claimed the possibility of 100% solar conversion efficiency.

Several authors have claimed that 100% collection efficiency in the transmission of microwave power should, in principle, be possible. Antenna texts routinely state that an aperture antenna can theoretically transfer to its load all the electromagnetic energy that impinges the aperture (Kraus, 1988, Balanis, 1997). That conclusion assumes uniform distribution of energy across the aperture, a load ideally matched to the antenna and single frequency, coherent operation. However, a receiving antenna with a resistive load must also transmit noise power according to the second law of thermodynamics and the principle of detailed balance. Under equilibrium conditions an antenna receiving power from a source and transferring it to a load must transmit the same amount of power back to the source in order to maintain equilibrium (see, for example, Burke and Graham-Smith, 1997, Pawsey and Bracewell, 1955). The origin of the transmitted power is the voltage generated in a conductor by thermal agitation of the charge carriers, known as Johnson or Nyquist noise, from the resistive load at the same effective temperature as the source. At frequencies below $\sim 10^{13}$ Hz a classical approximation suffices and the available white noise power from a resistor at absolute temperature, T , is kTB Watts, where k is Boltzmann's constant and B is the equivalent noise bandwidth (Hz) (Schwartz, 1990, Sec. 6-14). The noise is "white", having a frequency-independent power spectral density of $kT/2$. At higher frequencies, including the optical range, quantum effects are evident and the noise current spectral density is given by (Schwartz, 1990, Sec. 6-14)

$$G_i(f) = \frac{1}{2} \left[\frac{hf}{2} + \frac{hf}{\exp(hf/kT) - 1} \right].$$

The first term is due to the quantum mechanical zero point energy. This spectrum is not white, but decreases with frequency, particularly above h/kT , which is around 10^{13} Hz ($\lambda = 30 \mu\text{m}$) at room temperature. This re-radiated noise is commonly ignored by antenna engineers and their efficiency estimates are based on the ratio of incoming and reflected power at the signal frequency and that, in turn, is based on the analogous ratio in transmission mode according to the reciprocity theorem.

If power is extracted from the load, reducing its temperature, a new balance exists between the incoming, extracted and re-radiated powers. Hence, the solar energy conversion efficiency limit is expected to be the same as that for a solar thermal collector. That limit is 85.4% for a non-energy-selective collector with maximal concentration if we assume the Sun to be a 6000K black body and the surroundings to be at 300K (de Vos, 1992, ch. 5), in agreement with that stated by Berland et al. (2001). Multicolour thermal converters (de Vos, 1992, ch. 8) use multiple materials with different bandgaps to increase the efficiency limit, with maximal concentration and an infinite number of materials, to 86.8%. An infinite series of frequency-

selective filters offers the same advantage and the same limit in the case of rectennas.

There remains an open question about whether 86.8% is the ultimate limit and whether there may be scope for rectennas to reach the Landsberg limit of 93.3%. Ries (Ries, 1983) showed that the ultimate limit is theoretically achievable if time-reversal asymmetry can be invoked by use of a non-reciprocal absorber, for example, through the use of optical circulators. There is a tantalising suggestion that the presence of rectifying diodes may offer that benefit in rectennas. However, even if that were so, we must still consider the generation of noise by the rectifiers (Ambrózy, 1982). Shot noise is a fundamental consequence of the transport of quantised charge carriers across a potential barrier and the sharp current pulses due to carriers either becoming or ceasing to be minority carriers (van der Ziel and Becking, 1958). The noise power is proportional to the DC current through a rectifying barrier. Shot noise is often considered as an independent phenomenon to thermal noise but they have been shown to actually be special limits of a more general noise formula (Landauer, 1993). The shot noise form is evident when the mean free path is short compared to the sample size, as in most semiconductor junction devices.

6 SPECULATION ON POSSIBLE APPLICATIONS

6.1 Beam steering

It is common at microwave and millimeter wave frequencies to spatially steer the beam of a phased array antenna without any physical movement by controlling the phase of the signal from each element in the array. This suggests the future possibility of a concentrating solar energy collector with electronic pointing without moving parts.

6.2 Frequency up-conversion

The benefits available from up-conversion of sub-bandgap light passing through a bifacial solar cell have been outlined by Trupke et al. (Trupke et al., 2002). Low energy infrared photons can contribute to cell current if the energy of two or more can be consolidated in the production and emission of a super-bandgap photon by an up-converter. Trupke suggests the use of impurity levels to facilitate up-conversion.

Electromagnetic up-conversion is also possible through the generation of harmonic frequency components by non-linear loading, such as in one style of retail security tag (Crowley, 2000). Application of the effect at optical frequencies has previously been proposed (Crowley, 2000). Song (Song, 2002) suggests that artificial nonlinear nanomaterials have a quadratic response and should therefore generate second harmonics to the exclusion of higher ones.

Suppression of the re-radiation of harmonics is often a problem for the designers of rectennas (McSpadden et al., 1992) but it could be a benefit if several diode-loaded optical antennas could be located behind a bifacial solar cell with a reflector behind the antennas. Frequency-multiplied radiation could then radiate energy back to the rear of the cell and enhance its output. Sheets of polymer containing optical antennas and diodes may have possible application here (Marks, 1991). Song

suggests that his artificial nanomaterial should allow second harmonic generation without higher harmonics.

7 CONCLUSIONS

We have reviewed the history and principles of solar antennas and described their technological context. The thermodynamic limit on its performance was explained and quantified as 85.4% for concentrated solar input without frequency selectivity and 86.8% with selectivity. It remains an open question whether an ultimate limit exists closer to 93.3% but such considerations must account for all sources and consequences of electrical noise.

8 ACKNOWLEDGMENTS

The Special Research Centre for Third Generation Photovoltaics is supported by the Australian Research Council's Special Research Centres scheme. MAG acknowledges the support of a Federation Fellowship and RC is grateful to R. Gough and G. James (CSIRO) and N. Harder and G. Conibeer (UNSW) and H. Linke (U. Oregon) for helpful discussions and to J. Hansen for preparing the figures.

REFERENCES

- Ambrózy, A. (1982) *Electronic Noise*, McGraw-Hill.
- Anon., Mitchell Market Reports, Elsevier Science, (1992) Silicon Carbide, Vol. 1, Report no.
- Bailey, R. L. (1972) A proposed new concept for a solar-energy converter, *Journal of Engineering for Power*, April, 73.
- Bailey, R. L. (1980) *Solar-Electrics. Research and Development*, Ann Arbor Science, Ann Arbor.
- Bailey, R. L., Callahan, P. S. and Zahn, M., University of Florida, Engineering and Industrial Experiment Station, (1975) Electromagnetic wave energy conversion research, Report no. NASA-CR-145876 (N76-13591).
- Balanis C. (1997) *Antenna Theory. Analysis and Design*, (2nd Ed.) Wiley, New York.
- Belinicher, V. I. and Sturman, B. I. (1980) The photogalvanic effect in media lacking a center of symmetry, *Sov. Phys. Usp.*, **23**, 199.
- Berland, B., Simpson, L., Nuebel, G., Collins, T. and Lanning, B. (2001) In *National Center for Photovoltaics Program Review Meeting*, NREL, pp. 323-324.
- Brown, W. C. (1970) The receiving antenna and microwave power rectification, *Journal of Microwave Power*, **5**, 279-92.
- Brown, W. C. (1984) The history of power transmission by radio waves, *IEEE Transactions on Microwave Theory & Techniques*, **MTT-32**, 1230-1242.
- Burke, B. F. and Graham-Smith, F. (1997) *An Introduction to Radio Astronomy*, Cambridge University Press, Cambridge.
- Christodoulou, C. G. and Wahid, P. F. (2001) *Fundamentals of Antennas: Concepts and Applications*, SPIE, Bellingham.
- Corkish, R. and Green, M. A. (2002) In *PV in Europe*, WIP-Munich, Rome.
- Crowley, R. J. (2000) *Optical antenna array for harmonic generation, mixing and signal amplification*, USA Patent no. 6,038,060.
- de Vos, A. (1992) *Endoreversible thermodynamics of solar energy conversion*, Oxford Science, Oxford.
- Elchinger, G. M., Sanchez, A., Davis, C. F., Jr. and Javan, A. (1976) Mechanism of detection of radiation in a high-speed metal-metal oxide-metal junction in the visible region and at longer wavelengths, *Journal of Applied Physics*, **47**, 591-4.
- Elliott, R. S. (1963) Beamwidth and directivity of large scanning arrays, Part 1, *Microwave Journal*, **6**, 53-60.
- Fumeaux, C., Alda, J. and Boreman, G. D. (1999) Lithographic antennas at visible frequencies, *Optics Letters*, **24**, 1629-1631.

- Goswami, D. Y. (2001) In *Book of Abstracts, Solar World Congress, 25-30 November*(Ed, Saman, W.), Australian and New Zealand Solar Energy Society, Adelaide, pp. 6.
- Graham-Smith, F. and King, T. A. (2000) *Optics and Photonics: An Introduction*, Wiley, Chichester.
- Green, R. J., (2002), *Optical Antenna*, <http://www.eng.warwick.ac.uk/csp/optant.html>.
- Hirshman, W. P. (2001) Beam me down, Scotty. Will space solar power energize the earth?, *Photon International*, Oct, 8-10, 79.
- Konovaltsev, A. A., Luchaninov Yu, A., Omarov, M. A. and Shokalo, V. M. (2001) Developing wireless energy transfer systems using microwave beams: applications and prospects, *Telecommunications & Radio Engineering*, **55**, 21-9.
- Kraus, J. D. (1988) *Antennas*, (2nd Ed.) McGraw-Hill, New York.
- Landauer, R. (1993) Solid-state shot noise, *Physical Review B-Condensed Matter*, **47**, 16427-32.
- Lin, G. H., Abdu, R. and Bockris, J. O. M. (1996) Investigation of resonance light absorption and rectification by subnanostructures, *Journals of Applied Physics*, **80**, 565.
- Marks, A. M. (1984) *Device for conversion of light power to electric power*, USA Patent no. 4,445,050.
- Marks, A. M. (1986) *Ordered dipolar light-electric power converter*, USA Patent no. 4,574,161.
- Marks, A. M. (1988) *Femto diode and applications*, USA Patent no. 4,720,642.
- Marks, A. M. (1990) *Lighting devices with quantum electric/light power converters*, USA Patent no. 4,972,094.
- Marks, A. M. (1991) In *Proc. of the 26th Intersoc. Energy Conv. Eng. Conf.*, Vol. 5, Amer. Nucl. Soc., La Grange Park, IL, USA, pp. 74-78.
- Marks, A. M., Polarized Solar Electric Company (2002), <http://www.polar-solar.com/lumeloid.html>.
- McSpadden, J., Kai, C. and Patton, A. D. (1996) Microwave power transmission research at Texas A&M University, *Space Energy & Transportation*, **1**, 368-93.
- McSpadden, J. O., Fan, L. and Chang, K. (1998) Design and experiments of a high-conversion-efficiency 5.8-GHz rectenna, *IEEE Transactions on Microwave Theory and Techniques*, **46**, Dec, 2053-2060.
- McSpadden, J. O., Yoo, T. and Chang, K. (1992) Theoretical and experimental investigation of a rectenna element for microwave power transmission, *IEEE Transactions on Microwave Theory & Techniques*, **40**, 2359-66.
- Nahas, J. J. (1975) Modeling and computer simulation of a microwave-to-DC energy conversion element, *IEEE Transactions on Microwave Theory & Techniques*, **MTT-23**, 1030-1035.
- NIST, NIST (2002), *Optical nanoantennas and nanodiodes using atomic layer deposition*, <http://www.boulder.nist.gov/div814/nanotech/antennas>.
- Oesterschulze, E., Georgiev, G., Muller-Wiegand, M., Vollkopf, A. and Rudow, O. (2001) Transmission line probe based on a bow-tie antenna, *Journal of Microscopy-Oxford*, **202**, Apr, 39-44.
- Pawsey, J. L. and Bracewell, R. N. (1955) *Radio Astronomy*, Oxford, Clarendon Press, Oxford.
- Podolskiy, V. A., Sarychev, A. K. and Shalaev, V. M. (2002) Plasmon modes in metal nanowires and left-handed materials, *International Journal of Nonlinear Optical Physics*, **11**, Mar, 65-74.
- Raytheon, Raytheon Co., (1975) Reception - conversion subsystem (RXCV) for microwave power transmission System, Final Report, Report no. ER75-4386.
- Razban, T., Bouthinon, M. and Coumes, A. (1985) Microstrip circuit for converting microwave low power to DC energy, *IEE Proceedings, Part H*, **132**, 107-109.
- Reimann, P. (2002) Brownian motors: noisy transport far from equilibrium, *Physics Reports*, **361**, cp1-265.
- Ries, H. (1983) Complete and reversible absorption of radiation, *Applied Physics B-Photophysics & Laser Chemistry*, **B32**, 153-6.
- Schwartz, M. (1990) *Information Transmission, Modulation and Noise*, (4th Ed.) McGraw-Hill, New York.
- Song, A. M. (2002) Electron ratchet effect in semiconductor devices and artificial materials with broken centrosymmetry, *Applied Physics a-Materials Science & Processing*, **75**, Aug, 229-235.
- Trupke, T., Green, M. A. and Würfel, P. (2002) Improving Solar Cell Efficiencies by the Up-Conversion of Sub-Band-Gap Light, *Journal of Applied Physics*, **in press**.
- van der Ziel, A. and Becking, A. G. T. (1958) Theory of junction diode and junction transistor noise, *Proceedings IRE*, **46**, 589-594.
- Wang, S. (1976) Antenna properties and operation of metal-barrier-metal devices in the infrared and visible regions, *Appl Phys Lett*, **303**, 303-305.

FIGURE CAPTIONS

Fig. 1. Block diagram of rectenna and load.

Fig. 2. Kraus' solar rectenna concept (Kraus, 1988)

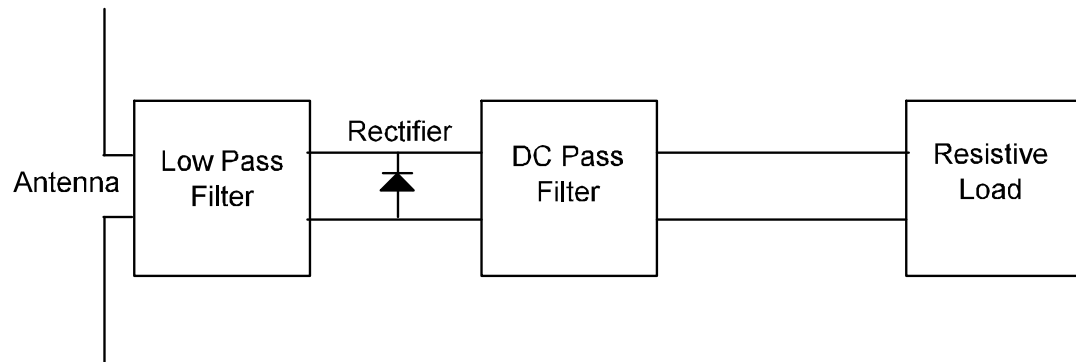

Fig. 1. Block diagram of rectenna and load.

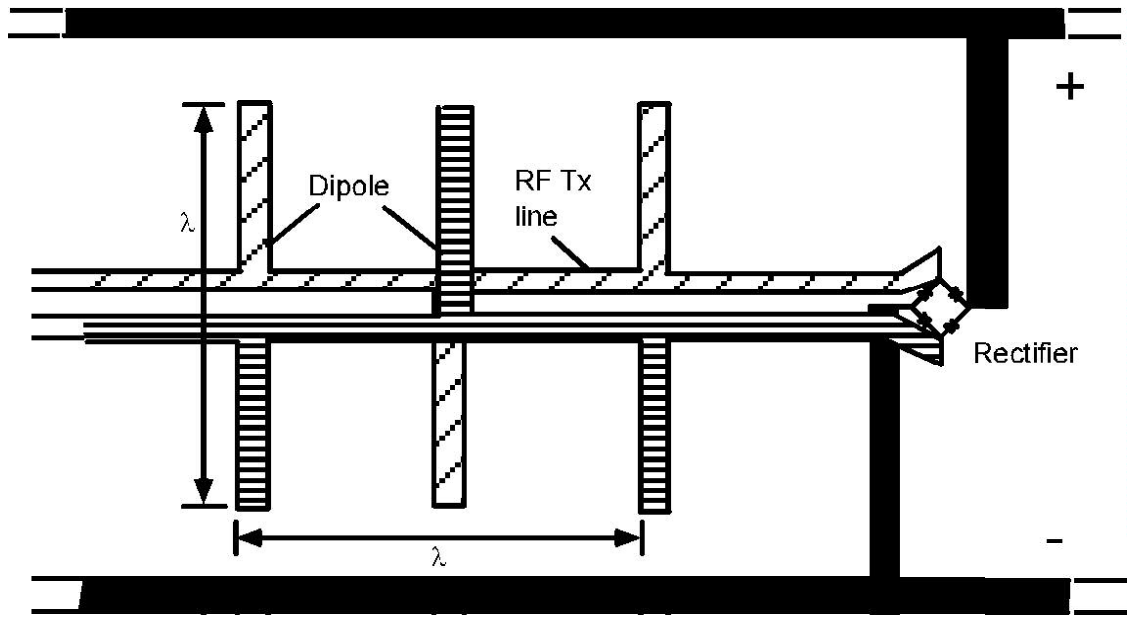

Fig. 2. Kraus' solar rectenna concept (Kraus, 1988)